



MANA 10.4-1P1

Product Description

Contact Details

Shenzhen EEnovance Energy Technology CO., LTD

Room 401, Building 2, Yufengda Industrial Park, No. 1008
Guangqiao Avenue, Yulu Community, Yutang Streets,
Guangming District, SHENZHEN.PRC.

Telephone: +86 755 8656 6313

Email: info@eenovance.com







CONTENTS

1 Technical Data	1-2
2 Product Overview	03
2.1 Brief Introduction	3
2.2 Interface Introduction	4
2.2.1 CAN / RS485 Port	5
2.2.2 RS232 Port	5
2.2.3 Link In / Link Out	5
2.2.4 LED Indicator Definition	6
3 Installation Guide	08
3.1 Checking Before Installation	9
3.1.1 Checking Outer Packing Materials	9
3.1.2 Checking Deliverables	9
3.2 Tools	10
3.3 Installation Requirements	10
3.3.1 Installation Environment Requirements	10
3.3.2 Installation Carrier Requirements	10
3.4 Installation Instructions	11
3.4.1 Dimensions	11
3.4.2 Installation Procedure	12-15
3.4.3 Power On/Off The Battery	16
4 Maintenance	17
4.1 Recharge Requirements During Normal Storage	17
4.2 Recharge Requirements When Over Discharged	17
5 Disposal Of The Battery System	18

01 TECHNICAL DATA

NOTE

Operating current derating according to the cell voltage and battery temperature.

-  **More Usable Energy**
Deep cycle DOD control
-  **Flexible Investment**
Up to 15 units in parallel
-  **Safe & Reliable**
Premium Lithium Iron Phosphate (LFP)
-  **Easy Installation**
Four wheels easy movement Floor stand
-  **Quick Commissioning**
One button ON/OFF Automatic ID assignment
-  **Universal Compatibility**
Compatible with major PCS brands
-  **Auto aerosol fire extinguishing**
Ultimate security, strengthen defenses



Datasheet

Model	MANA 10.4-1P1
-------	---------------

Performance	
Cell Technology	LiFePO ₄ , Lithium Iron Phosphate
Nominal Voltage	51.2 Vdc
Nominal Capacity	205 Ah
Battery Usable Energy ^[1]	10496 Wh
Operating Voltage	44.8 - 56.16 Vdc
Nominal Charge And Discharge Current	102.5 A
Max. Charge And Discharge Current ^[2]	200 A

Communication	
Display	LED indicator
Communication	CAN / RS485 / RS232 / Wi-Fi

General Specification	
Dimension (W×D×H)	530×245×675 mm
	20.9×9.6×26.6 inch
Weight	86 kg (189.6 lbs)
Installation	Floor stand or Wall mounted
Operating Temperature ^[3]	Charge : 0 to 50°C (32 to 122°F) Discharge: -15 to 50°C (5 to 122°F)
Operating / Storage / Humidity	≤ 95%RH
Ingress Protection Rating	IP 65
Scalability	Max 15 batteries in parallel

Standard Compliance	
Compliance	UN38.3, IEC62619, IEC61000 (more available upon request)

[1] Test conditions: 100% depth of discharge (DOD), 0.2C rate charge & discharge at 25°C.

[2] There is 0.5C or 1C configurations optional in factory default.

[3] Charge/discharge derating occurs when the temperature is below 0°C or above 45°C.

02 PRODUCT OVERVIEW

2.1 Brief Introduction

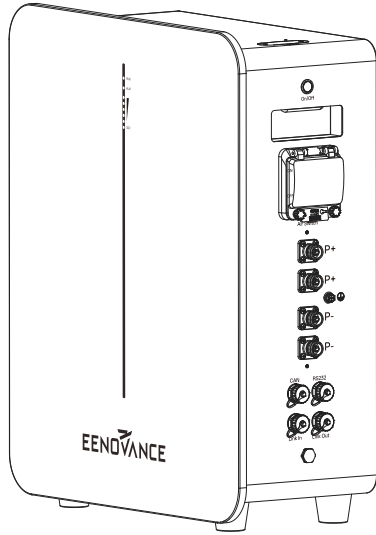

PRODUCT OVERVIEW

MANA 10.4-1P1 is a lithium battery with an operating voltage range of 44.8~56.16V. It is designed for residential energy storage applications and is compatible with 48V battery hybrid inverter. MANA 10.4-1P1 is not suitable for supporting life-sustaining medical devices.

MANA 10.4-1P1 has built-in BMS (Battery Management System), which can manage and monitor cells information including voltage, current and temperature. Besides that, BMS can balance cells charging to extend cycle life. BMS has protection functions including over-discharge, over-charge, over-current and high / low temperature; the system can automatically manage the charge state, discharge state, and balance state.

Up to 15 MANA 10.4-1P1 can be connected in parallel to increase capacity and power.

2.2 Interface Introduction

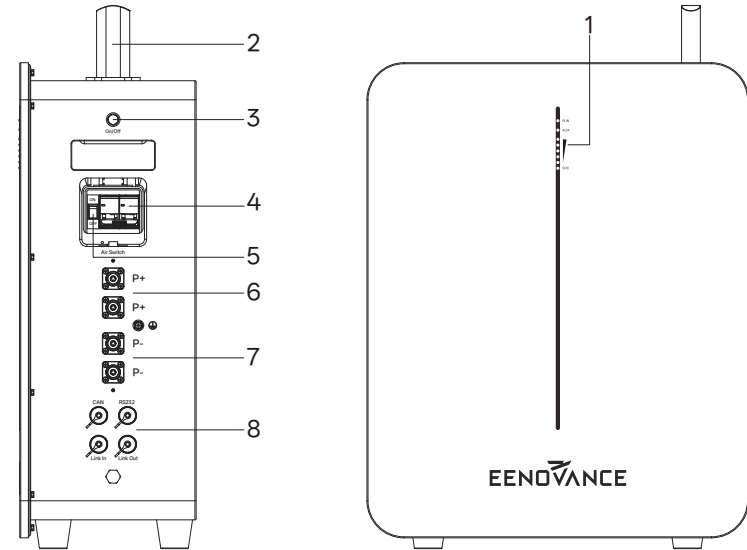

Operation interface description:

Serial Number	Name	Description
1	Status indicator	Operation, alarm, and SOC status
2	WiFi interface	Connect to WiFi module
3	On / Off	Reset switch
4	Air switch	Output switch (125A)
5	Rocker switch	Weak current switch
6	Positive terminal	Total positive terminal
7	Negative terminal	Total negative terminal
8	Communication port	Communication interface

2.2.1 CAN / RS485 Port

CAN / RS485 Communication terminal (RJ45 port) connects to inverter and operates using the CAN / RS485 protocol.

PIN	Definition
Pin 1, Pin 8	RS485-B (to Inverter, reserved)
Pin 2, Pin 7	RS485-A (to Inverter, reserved)
Pin 3	NC
Pin 4	CANH (to Inverter)
Pin 5	CANL (to Inverter)
Pin 6	GND

2.2.2 RS232 Port

RS232 terminal (RJ45 port) uses the RS232 protocol and is for manufacturer or engineer servicing or professional engineers to debug.

PIN	Definition
Pin 1, Pin 8	GND
Pin 2, Pin 7	RS232_TX
Pin 3, Pin 6	RS232_RX
Pin 4, Pin 5	NC

2.2.3 Link In / Link Out

Link In/Link Out terminal (RJ45 port) is used for battery parallel communication.

PIN	Link in
Pin1	NC
Pin2, Pin7	RS485-A (Parallel communication)
Pin3, Pin6	RS485-B (Parallel communication)
Pin4	UP IN+ (Parallel address)
Pin5	UP IN- (Parallel address)
Pin8	GND

PIN	Link out
Pin1	NC
Pin2, Pin7	RS485-A (Parallel communication)
Pin3, Pin6	RS485-B (Parallel communication)
Pin4	DN OP+ (Parallel address)
Pin5	DN OP- (Parallel address)
Pin8	GND

2.2.4 LED Indicator Definition

Note :

flash 1- 0.25s light / 3.75s off

flash 2- 0.5s light / 0.5s off

flash 3- 0.5s light / 1.5s off

LED Indicators Instructions

Status	RUN	ALM	Battery Level Indicator							Descriptions	
	L8	L7	L6	L5	L4	L3	L2	L1			
Shut down	OFF	OFF	OFF	OFF	OFF	OFF	OFF	OFF	OFF	All OFF	
Standby	Flash 1	OFF	According to the battery level							Indicates Standby	
Charging	Normal	Light	OFF	According to the battery level							The highest capacity indicator LED flashes(flash 2), others lighting Turn to standby status when charger off
	Full Charged	Light	OFF	Light	Light	Light	Light	Light	Light	Light	
	Protection	OFF	Light	OFF	OFF	OFF	OFF	OFF	OFF	OFF	
Discharge	Normal	Flash 3	OFF	According to the battery level							
	UVP	OFF	OFF	OFF	OFF	OFF	OFF	OFF	OFF	OFF	Stop charging
	Protection	OFF	Light	OFF	OFF	OFF	OFF	OFF	OFF	OFF	Stop discharge
Fault	OFF	Light	OFF	OFF	OFF	OFF	OFF	OFF	OFF	Stop charging and discharge	

Charging Battery Level Indicators Instructions

Status	Charging								
	L8	L7	L6	L5	L4	L3	L2	L1	
Battery Level Indicator									
Battery Level (%)	0~17%	Light	OFF	OFF	OFF	OFF	OFF	OFF	Flash 2
	18~33%			OFF	OFF	OFF	OFF	Flash 2	Light
	34~50%			OFF	OFF	OFF	Flash 2	Light	Light
	51~66%			OFF	OFF	Flash 2	Light	Light	Light
	67~83%			Flash 2	Light	Light	Light	Light	Light
	84~100%			Flash 2	Light	Light	Light	Light	Light
Full Charged	Light	Light	Light	Light	Light	Light	Light		

Discharging Battery Level Indicators Instructions

Status		Discharge							
		L8	L7	L6	L5	L4	L3	L2	L1
Battery Level Indicator		●	●	●	●	●	●	●	●
Battery Level (%)	0~17%	Flash 3	OFF	OFF	OFF	OFF	OFF	OFF	Light
	18~33%			OFF	OFF	OFF	OFF	Light	Light
	34~50%			OFF	OFF	OFF	Light	Light	Light
	51~66%			OFF	Light	Light	Light	Light	Light
	67~83%			Light	Light	Light	Light	Light	Light
84~100%	Light	Light	Light	Light	Light	Light	Light		

Protection Fault Indicators Instructions

Status	Protection Fault							
	L8	L7	L6	L5	L4	L3	L2	L1
Status Battery Level Indicator	●	●	●	●	●	●	●	●
Battery Level(%)			84~100%	67~83%	51~66%	34~50%	18~33%	0~17%
Cell failure	OFF / Light	Light	OFF	OFF	OFF	OFF	OFF	OFF
NTC failure			Light	OFF	OFF	OFF	OFF	OFF
Precharge failure			OFF	Light	OFF	OFF	OFF	OFF
Short circuit fault			Light	Light	OFF	OFF	OFF	OFF
Charging MOS failure			OFF	OFF	Light	OFF	OFF	OFF
Discharge MOS fault			Light	OFF	Light	OFF	OFF	OFF
Precharge failure			OFF	Light	Light	OFF	OFF	OFF
Total negative contact failure			Light	Light	Light	OFF	OFF	OFF
Overvoltage protection of charging cells			OFF	OFF	OFF	Light	OFF	OFF
Overall charging overvoltage protection			Light	OFF	OFF	Light	OFF	OFF
Charging overcurrent protection			OFF	Light	OFF	Light	OFF	OFF
Discharge cell undervoltage protection			Light	Light	OFF	Light	OFF	OFF
Discharge overall undervoltage protection			OFF	OFF	Light	Light	OFF	OFF
Discharge overcurrent protection			Light	OFF	Light	Light	OFF	OFF
Charging high-temperature protection			OFF	Light	Light	Light	OFF	OFF
Charging low-temperature protection			Light	Light	Light	Light	OFF	OFF
High-temperature protection for discharge			OFF	OFF	OFF	OFF	Light	OFF
Discharge low-temperature protection			Light	OFF	OFF	OFF	Light	OFF
MOS tube high-temperature protection			OFF	Light	OFF	OFF	Light	OFF
Environmental low-temperature protection			Light	Light	OFF	OFF	Light	OFF
Ambient high-temperature protection	OFF	OFF	Light	OFF	Light	OFF		

Notes:
 1. In normal operation the ALM fault lamp is off and the the SOC lamp is indicates power. When a fault occurs, the ALM lamp turn on and the SOC lamp is displays as the fault code (in priority order from low light), if multiple protection faults exist, the RUN lamp will also remain on.

03 INSTALLATION GUIDE

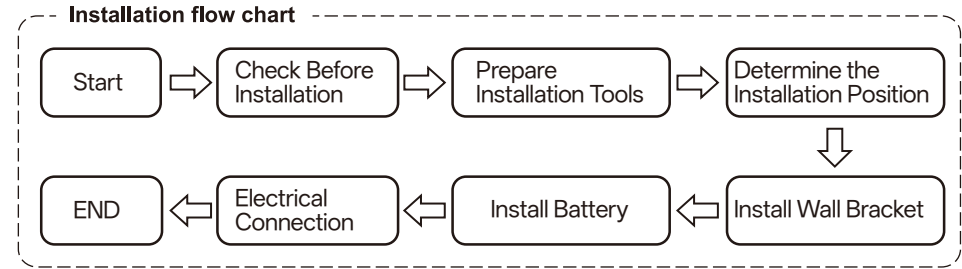

3.1 Checking Before Installation

3.1.1 Checking Outer Packing Materials









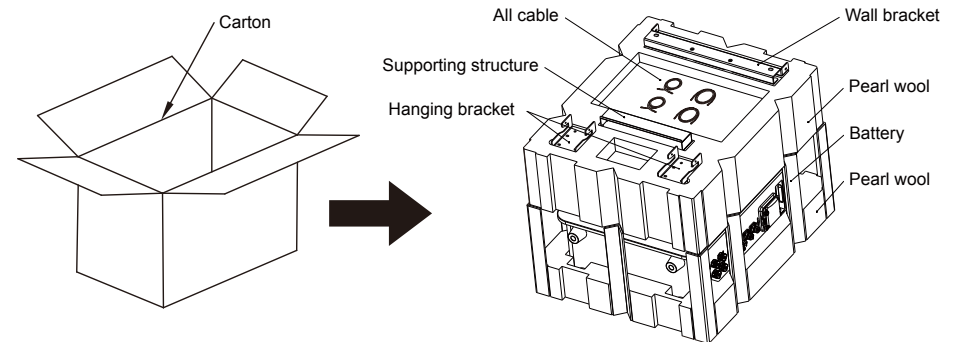



Packing materials and components may be damaged during transportation. Therefore, check the outer packing materials before installing the battery. Checking the surface of packing materials for damage, such as holes and cracks. If any damage is found, do not unpack the battery and contact the dealer as soon as possible. You are advised to remove the packing materials within 24 hours before installing the battery.

3.1.2 Checking Deliverables

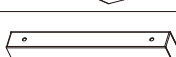









After unpacking the battery, check whether deliverables are intact and complete. If any damage is found or any component is missed, contact the dealer.

The below table shows the components and mechanical parts that should be delivered.



ON.	Pictures	Quantity	Description
1		1PCS	Battery
2		1PCS	Positive power cable
3		1PCS	Negative power cable
4		1PCS	PE cable
5		1PCS	Communication cable
6		1PCS	Wall bracket
7		2PCS	Hanging bracket
8		1PCS	Supporting structure
9		4PCS	M10*60
10		2PCS	M4*20
11		10PCS	M6*16
12		1PCS	Test report
13		1PCS	QA certificate

3.2 Tools

Model	Tools		
Installation	Knife 	Measuring tape 	Socket wrench (10/16mm) 
	Rubber mallet 	Cross screwdriver 	Hammer drill (12mm) 
Protection	ESD gloves 	Safety goggles 	Anti-dust respirator 
	Safety shoes 		

3.3 Installation Requirements

3.3.1 Installation Environment Requirements

- Install the battery in the indoor environment.
- Place battery in secure location away from children and animals.
- Do not place the battery near any heat sources and avoid sparks.
- Do not expose the battery to moisture or liquids.
- Do not expose the battery to direct sunlight.

3.3.2 Installation Carrier Requirements

- Install the battery only on fire resistant structures. Do not install batteries on flammable buildings.
- Battery is quite heavy, make sure the wall/ground can meet the load bearing requirements.

3.4 Installation Instructions

3.4.1 Dimensions

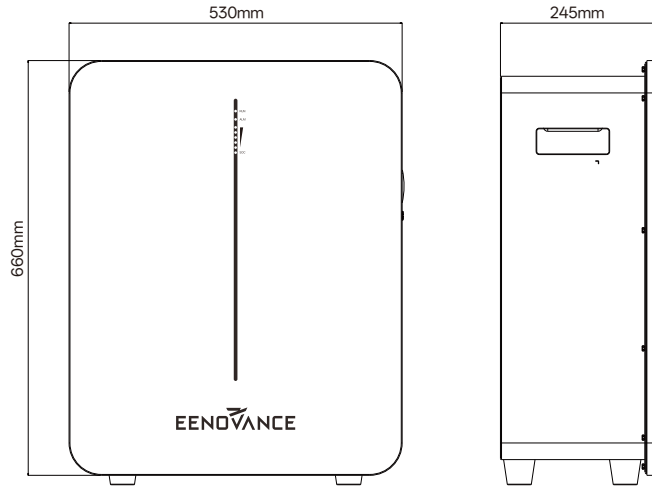

Minimum mounting distance between the battery pack and equipment:

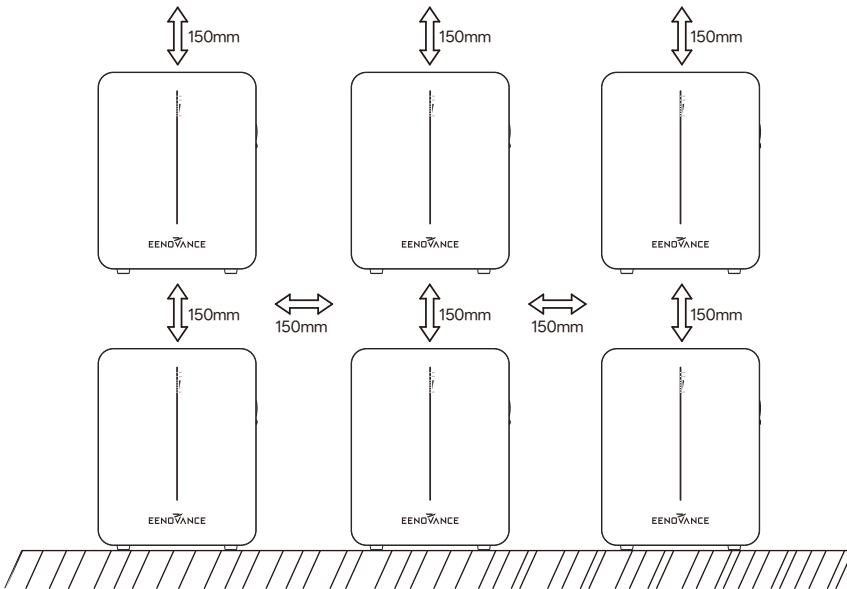

3.4.2 Installation Procedure

STEP 1

Drill the hole with a 12mm drill bit as follows and fix the wall bracket to the wall.

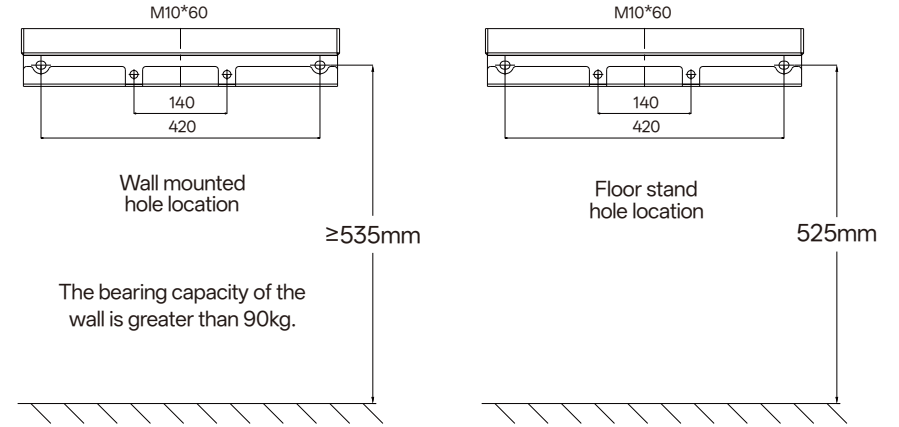

STEP 2

Install the hanging bracket.

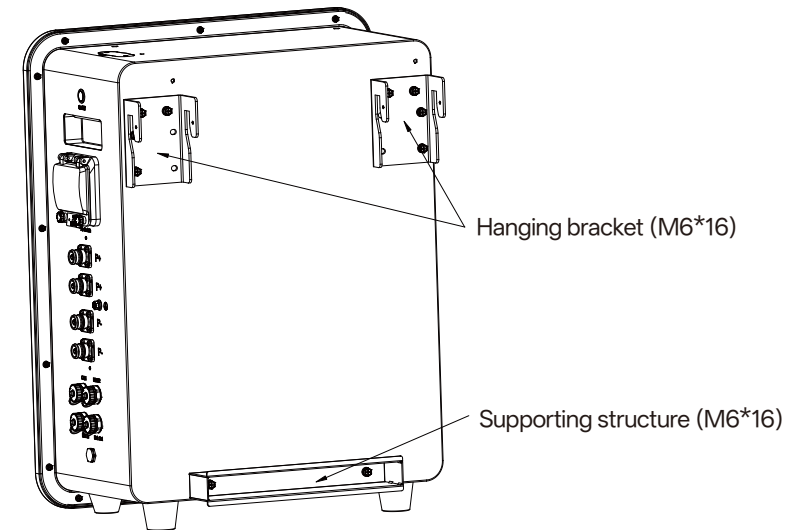

STEP 3

Hang MANA 10.4-1P1 on the wall bracket and tighten it.

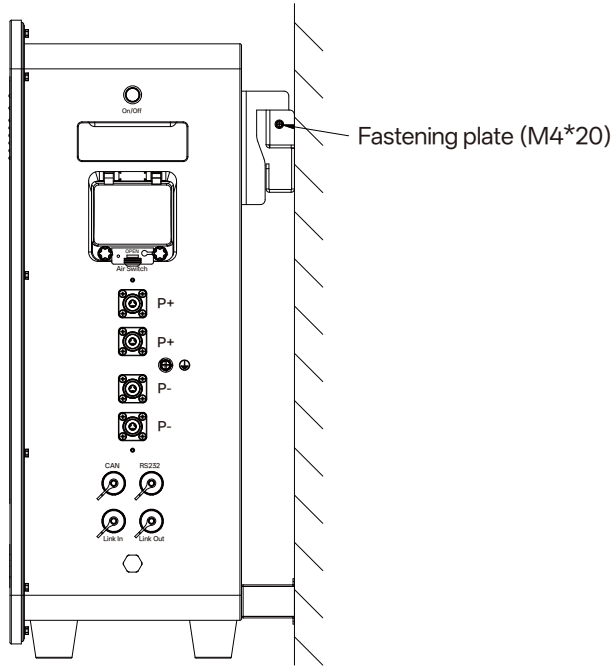

STEP 4

Connected to the ground.

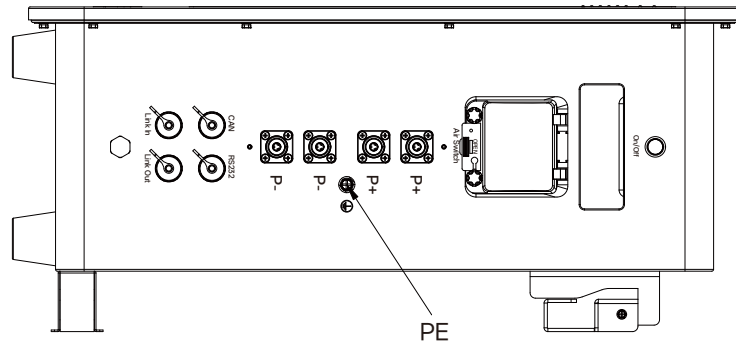

STEP 5

Connect the power cable.

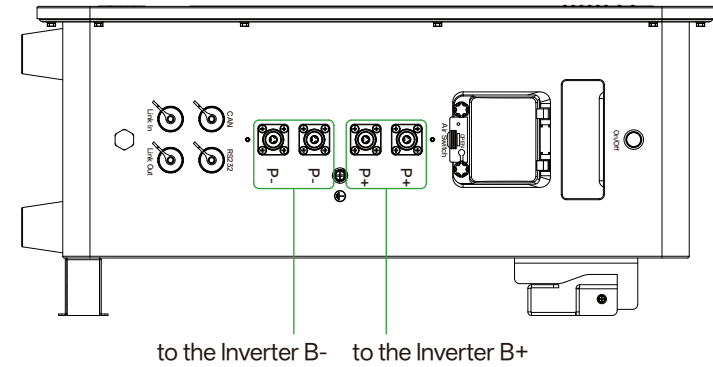

STEP 6

Connect the communication cable.

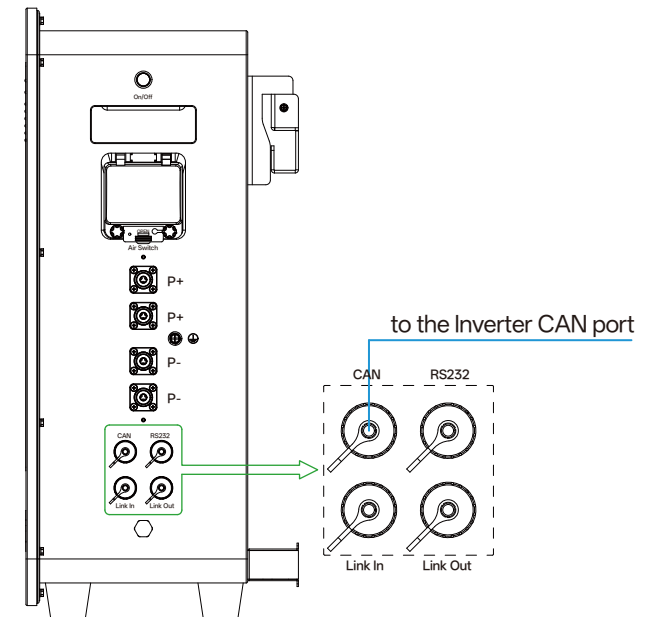

STEP 7

When connecting multiple batteries in parallel, use the wiring method shown below, and then install a Wi-Fi stick on the host unit.

Scheme One (Inverter Power ≤ 10KW)

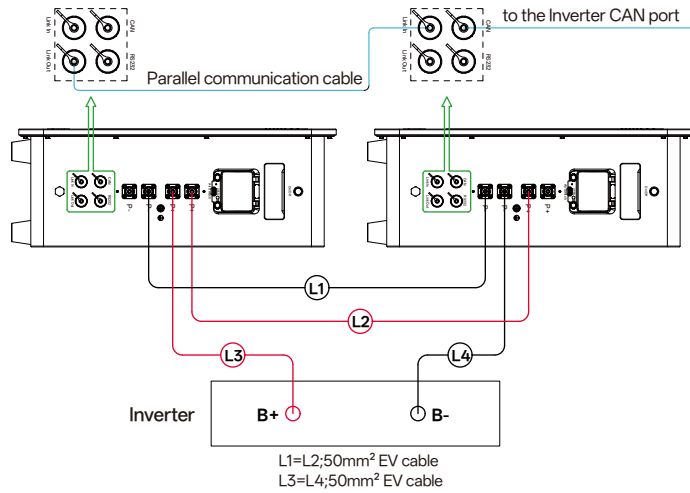

Scheme Two (Inverter Power > 10KW)

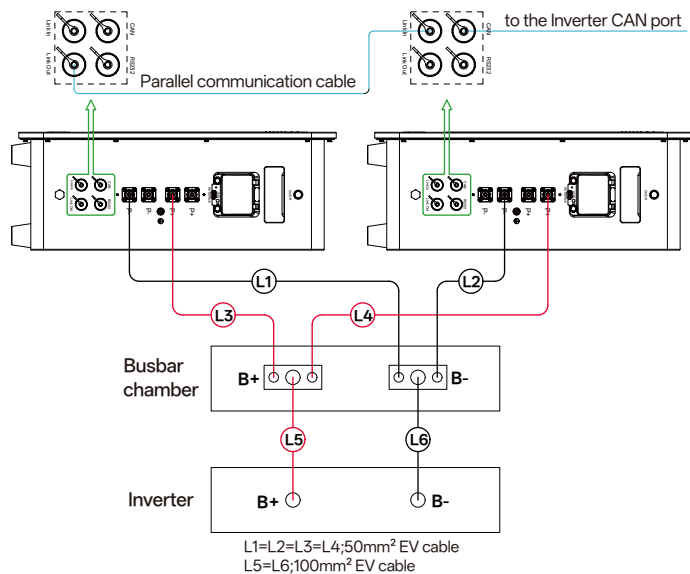

3.4.3 Power On/Off The Battery

1. Power ON

For a single MANA 10.4-1P1, switch on the rocker switch and then press and hold ON / OFF button for more than 3 seconds. LED will flash and the battery will begin normal operation.

Indicators L1 to L6 displays battery SOC, while L7/L8 displays battery status.

For multiple MANA 10.4-1P1 in parallel, switch on the rocker switch of all batteries, and press and hold ON / OFF button on the master battery for more than 3 seconds, LED will flash, the battery system will automatically encode and assign ID to each slave battery, then the battery system will then begin normal operation.

2. Power OFF

Press the ON / OFF button of the master battery more than 3 seconds and then release the button, the master battery will shut down after all slave batteries enter the sleep mode.

For a single MANA 10.4-1P1, simply switch off the rocker switch.

For multiple MANA 10.4-1P1 in parallel, switch off the rocker switch of all slave batteries first. Then switch off the rocker switch of the master battery.

04 MAINTENANCE

4.1 Recharge Requirements During Normal Storage

Battery should be stored in an environment with temperature range between -10°C ~ +45°C, and maintained regularly according to following table with 0.5C (102.5A) current till 40% SOC after long storage time.

Recharge Conditions When in Storage

Storage Environment Temperature	Relative Humidity of Storage Environment	Storage Time	SOC
Below -10°C	/	Prohibit	/
-10~25°C	5%~70%	≤12 months	30% ≤SOC≤60%
25~35°C	5%~70%	≤6 months	30% ≤SOC≤60%
35~45°C	5%~70%	≤3 months	30%≤SOC≤60%
Above 45°C	/	Prohibit	/

4.2 Recharge Requirements When Over Discharged

The over-discharged (90% DOD) battery should be recharged according to the following table, otherwise the over-discharged battery will be damaged.

Recharge Conditions When Battery is Over Discharged

Storage Environment Temperature	Storage Time	Note
-10~25°C	≤15 days	Battery Pack disconnected from Inverter
25~35°C	≤7 days	
-10~45°C	<12 hours	Battery Pack connected to Inverter

05 DISPOSAL OF THE BATTERY SYSTEM

Disposal of the battery must comply with the local applicable disposal regulations for electronic waste and used batteries.

- Do not dispose of the battery system with your household waste.
- Avoid exposing the batteries to high temperatures or direct sunlight.
- Avoid exposing the batteries to high humidity or corrosive atmospheres.