

ENERGY TECHNOLOGIES  
BUILD LIFE BETTER

RESIDENTIAL  
BATTERY



## MANA 5.12 Ultra Product Description

### Contact Details

**Shenzhen EEnovance Energy Technology CO., LTD**  
Room 401, Building 2, Yufengda Industrial Park, No. 1008  
Guangqiao Avenue, Yulv Community, Yutang Streets,  
Guangming District, SHENZHEN.PRC.  
Telephone: +86 755 8656 6313  
Email: [info@eenovance.com](mailto:info@eenovance.com)

Copyright©2024 Shenzhen EEnovance Energy Technology Co., Ltd. All rights reserved.  
EN V1.3 2020512

**EENOVANCE**

[eenovance.com](http://eenovance.com)

# CONTENTS

<b>1</b>	<b>Technical Data</b>	<b>1-2</b>
<b>2</b>	<b>Product Overview</b>	<b>3</b>
2.1	Brief Introduction	3
2.2	Interface Introduction	4
2.2.1	Switch ON / OFF	4-5
2.2.2	LED Indicator Definition	5-6
2.2.3	CAN / RS485 Port	7
2.2.4	RS232 Port	7
<b>3</b>	<b>Installation Guide</b>	<b>8</b>
3.1	Checking Before Installation	8
3.1.1	Checking Outer Packing Materials	8
3.1.2	Checking Deliverables	8-9
3.2	Tools	10
3.3	Installation Requirements	10
3.3.1	Installation Environment Requirements	10
3.3.2	Installation Carrier Requirements	10
3.4	Installation Instructions	11
3.4.1	Dimensions	11
3.4.2	Installation Procedure	12-16
<b>4</b>	<b>Maintenance</b>	<b>17</b>
4.1	Recharge Requirements During Normal Storage	17
4.2	Recharge Requirements When Over Discharged	17
<b>5</b>	<b>Disposal Of The Battery System</b>	<b>18</b>

# 01 TECHNICAL DATA

## NOTE

The battery is not rated 1C continuously. Operating current derating according to the cell voltage and battery temperature.

**Safe and Reliable**  
Meet diverse home energy needs with LFP batteries that offer 6000 cycles for longer-lasting performance, and with IP65 protection, ensuring higher safety for your peace of mind.

**Hassle-Free Setup**  
Easily choose between floor or wall installation, and effortless maintenance.

**Flexible and Expandable**  
Easily connect up to 15 units in parallel, don't worry about future power increases in your home.

**Smart Home**  
Use your smartphone to control your home energy freely.



## DATASHEET

Model	MANA 5.12 Ultra
-------	-----------------

### Performance

Cell technology	LFP ( LiFePO <sub>4</sub> )
Battery usable energy [1]	5.120 kWh
Nominal voltage	51.2 V
Operating voltage	44.8 - 56.16 V
Max. charge and discharge current [2]	98 A

### Communication

Display	SOC status indicator, LED indicator
Communication	CAN / RS485 / RS232 / Wi-Fi

### General Specification

Dimension (W×D×H)	470×160×635 mm
	18.5×63×25 inch
Weight	48.8 kg (107.5 lbs)
Installation	Floor stand or wall mounted
Operating temperature [3]	Charge: 0 to 50°C (32 to 122°F) Discharge: -15 to 50°C (5 to 122°F)
Environmental humidity	≤ 95%RH (No condensation)
Ingress protection rating	IP 65
Cycle life [4]	6000 Cycles or ten (10) years @ 80% DOD / 25°C / 0.5C, 70% EOL
Application	ON Grid / ON Grid + Backup / OFF grid
Compatible inverters	Refer to compatible inverter list (Compatible with major PCS brands)

### Standard Compliance

Compliance	UN38.3 / IEC62619 / IEC61000 / IEC62040-1 / FCC / UL1973 / UL9540A (More available upon request)
------------	--

### Ordering and Deliverable Part

Part	MANA 5.12 Ultra Battery
	MANA 5.12 Ultra Parallel cable
	MANA 5.12 Ultra to PCS cable

(1) Test conditions: 100% depth of discharge (DOD), 0.2C rate charge & discharge at 25°C.  
 (2) There is 0.5C or 1C configurations optional in factory default.  
 (3) Charge/discharge derating occurs when the temperature is below 0°C or above 45°C.  
 (4) Please refer to the Warranty Letter for applicable conditions, the warranty is due whichever comes first.

# 02 PRODUCT OVERVIEW

## 2.1 Brief Introduction

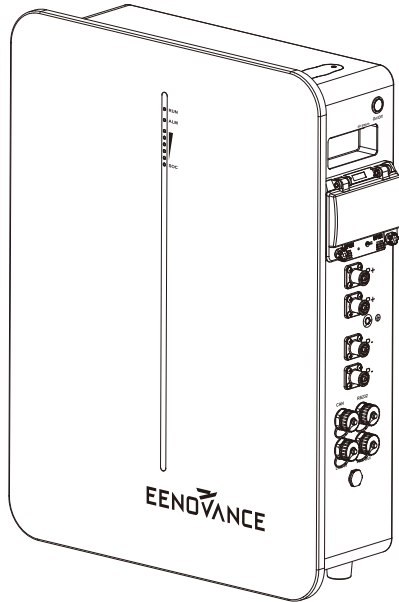

PRODUCT OVERVIEW

MANA 5.12 Ultra is a lithium battery with an operating voltage range between 44.8~56.16V. it is designed for residential energy storage applications and works together with a 48V battery hybrid inverter. MANA 5.12 Ultra is not suitable for supporting life-sustaining medical devices.

MANA 5.12 Ultra has built-in BMS (Battery Management System), which can manage and monitor cells information including voltage, current and temperature. Besides that, BMS can balance cells charging to extend cycle life. BMS has protection functions including over-dis-charge, over-charge, over-current and high / low temperature; the system can automatically manage the charge state, discharge state and balance state.

## 2.2 Interface Introduction

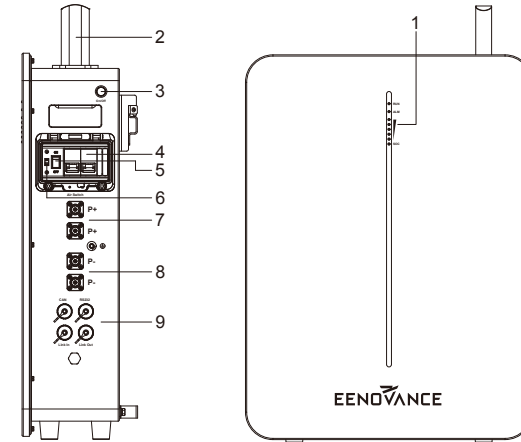

Operation interface description:

Serial Number	Name	Description
1	Status indicator	Operation, alarm, and SOC status
2	WiFi interface	Connect to WiFi module
3	On / Off	Reset switch
4	Air switch	Output switch
5	POWER	Weak current switch
6	Slide switch	BMS power supply switch
7	Positive terminal	Total positive terminal
8	Negative terminal	Total negative terminal
9	Communication port	Communication interface

### 2.2.1 Switch ON / OFF

#### 1. Switch ON

For a single MANA 5.12 Ultra, firstly, the Air switch (4), Slide switch (6) and POWER (5) are in the ON state, then long press (over 3 seconds) On / Off (3), LED will flash, and the battery will work normally. L1 to L6 shows battery SOC, and L7 / L8 shows battery status. For multiple MANA 5.12 Ultra in parallel, firstly, the Air switch (4), Slide switch (6) and POWER (5) of all batteries are in the ON state, long press (more than 3 seconds) On / Off button of the Master battery, LED will flash, and the battery system will automatically encode and assign ID to each slave battery, then the battery system will operate normally.

2.Switch OFF

Press the start button of the Master pack more than 3s and then release the button, the master pack will shut down after all slave packs shut down (sleep mode).

For a single MANA 5.12 Ultra, switch OFF POWER (5) and Air switch (4).

For multiple MANA 5.12 Ultra in parallel, switch OFF POWER (5) and Air switch (4) on all slave batteries first. Then switch OFF POWER (5) and Air switch (4) on the Master battery.

2.2.2 LED Indicator Definition

Note:

flash 1 - 0.25s light / 3.75s off

flash 2 - 0.5s light / 0.5s off

flash 3 - 0.5s light / 1.5s off

LED Indicators Instructions

Status	RUN	ALM	Battery Level Indicator						Descriptions	
	L8	L7	L6	L5	L4	L3	L2	L1		
Shut down	OFF	OFF	OFF	OFF	OFF	OFF	OFF	OFF	All OFF	
Standby	Flash 1	OFF	According to the battery level						Indicates Standby	
Charging	Normal	Light	OFF	According to the battery level						The highest capacity indicator LED flashes(Flash 2), others lighting
	Full Charged	Light	OFF	Light	Light	Light	Light	Light	Light	Turn to standby status when charger off
	Protection	OFF	Light	OFF	OFF	OFF	OFF	OFF	OFF	Stop charging
Discharge	Normal	Flash 3	OFF	According to the battery level						
	UVP	OFF	OFF	OFF	OFF	OFF	OFF	OFF	OFF	Stop charging
Protection	OFF	Light	OFF	OFF	OFF	OFF	OFF	OFF	OFF	Stop discharge
Fault	OFF	Light	OFF	OFF	OFF	OFF	OFF	OFF	OFF	Stop charging and discharge

Charging Battery Level Indicators Instructions

Status	Charging								
	L8	L7	L6	L5	L4	L3	L2	L1	
Battery Level Indicator									
Battery Level (%)	0~17%	Light	OFF	OFF	OFF	OFF	OFF	OFF	Flash 2
	18~33%			OFF	OFF	OFF	OFF	Flash 2	Light
	34~50%			OFF	OFF	OFF	Flash 2	Light	Light
	51~66%			OFF	OFF	Flash 2	Light	Light	Light
	67~83%			OFF	Flash 2	Light	Light	Light	Light
	84~100%			Flash 2	Light	Light	Light	Light	Light
Full Charged	Light	Light	Light	Light	Light	Light	Light		

Discharging Battery Level Indicators Instructions

Status	Discharge									
	L8	L7	L6	L5	L4	L3	L2	L1		
Battery Level Indicator										
Battery Level (%)	0~17%	Flash 3	OFF	OFF	OFF	OFF	OFF	OFF	Light	
	18~33%			OFF	OFF	OFF	OFF	Light	Light	
	34~50%			OFF	OFF	OFF	Light	Light	Light	Light
	51~66%			OFF	OFF	Light	Light	Light	Light	Light
	67~83%			OFF	Light	Light	Light	Light	Light	Light
	84~100%			Light	Light	Light	Light	Light	Light	Light

Protection Fault Indicators Instructions

Status	Protection Fault							
	L8	L7	L6	L5	L4	L3	L2	L1
Status Battery Level Indicator								
Battery Level(%)			84 ~ 100%	67 ~ 83%	51 ~ 66%	34 ~ 50%	18 ~ 33%	0 ~ 17%
Cell failure	OFF / Light	Light	OFF	OFF	OFF	OFF	OFF	OFF
NTC failure			Light	OFF	OFF	OFF	OFF	OFF
Precharge failure			OFF	Light	OFF	OFF	OFF	OFF
Short circuit fault			Light	Light	OFF	OFF	OFF	OFF
Charging MOS failure			OFF	OFF	Light	OFF	OFF	OFF
Discharge MOS fault			Light	OFF	Light	OFF	OFF	OFF
Precharge failure			OFF	Light	Light	OFF	OFF	OFF
Total negative contact failure			Light	Light	Light	OFF	OFF	OFF
Overvoltage protection of charging cells			OFF	OFF	OFF	Light	OFF	OFF
Overall charging overvoltage protection			Light	OFF	OFF	Light	OFF	OFF
Charging overcurrent protection			OFF	Light	OFF	Light	OFF	OFF
Discharge cell undervoltage protection			Light	Light	OFF	Light	Light	OFF
Discharge overall undervoltage protection			OFF	OFF	Light	Light	OFF	OFF
Discharge overcurrent protection			Light	OFF	Light	Light	OFF	OFF
Charging high-temperature protection			OFF	Light	Light	Light	OFF	OFF
Charging low-temperature protection			Light	Light	Light	Light	OFF	OFF
High-temperature protection for discharge			OFF	OFF	OFF	OFF	Light	OFF
Discharge low-temperature protection			Light	OFF	OFF	OFF	Light	OFF
MOS tube high-temperature protection			OFF	Light	OFF	OFF	Light	OFF
Environmental low-temperature protection			Light	Light	OFF	OFF	Light	OFF
Ambient high-temperature protection	OFF	OFF	Light	OFF	Light	OFF		

Notes: 1. The fault lamp ALM is not on in a normal state, at this time the SOC lamp is used as a power indication, the fault lamp ALM is always on when the fault occurs, and the SOC lamp is on according to the fault sequence number (priority sequence number from low light). If a variety of protection faults exist, the RUN lamp also needs to be on constantly.

### 2.2.3 CAN / RS485 Port

CAN / RS485 Communication Terminal (RJ45 port), connects to inverter, and follows CAN / RS485 protocol.

PIN	Definition
Pin 1, Pin 8	RS485-B ( to Inverter, reserved)
Pin 2, Pin 7	RS485-A ( to Inverter, reserved)
Pin 3	NC
Pin 4	CANH ( to Inverter)
Pin 5	CANL ( to Inverter)
Pin 6	GND

### 2.2.4 RS232 Port

RS232 Communication Terminal (RJ45 port) follows RS232 protocol, for manufacturers or professional engineers to debug or service.

PIN	Definition
Pin 1, Pin 8	GND
Pin 2, Pin 7	RS232_TX
Pin 3, Pin 6	RS232_RX
Pin 4, Pin 5	NC

## 03 INSTALLATION GUIDE

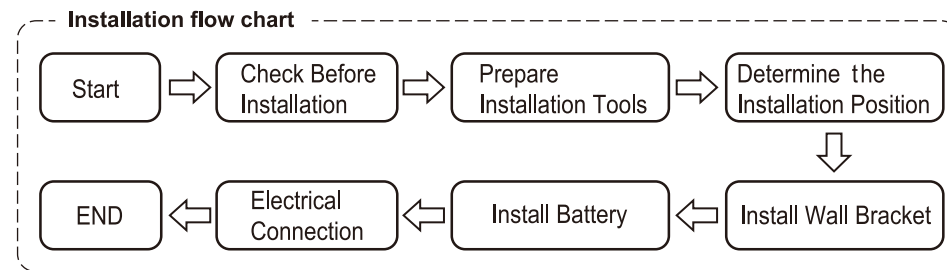

### 3.1 Checking Before Installation

#### 3.1.1 Checking Outer Packing Materials

Packing materials and components may be damaged during transportation. Therefore, check the outer packing materials before installing the battery. Checking the surface of packing materials for damage, such as holes and cracks. If any damage is found, do not unpack the battery and contact the dealer as soon as possible. You are advised to remove the packing materials within 24 hours before installing the battery.

#### 3.1.2 Checking Deliverables

After unpacking the battery, check whether deliverables are intact and complete. If any damage is found or any component is missed, contact the dealer.

The below table shows the components and mechanical parts that should be delivered.

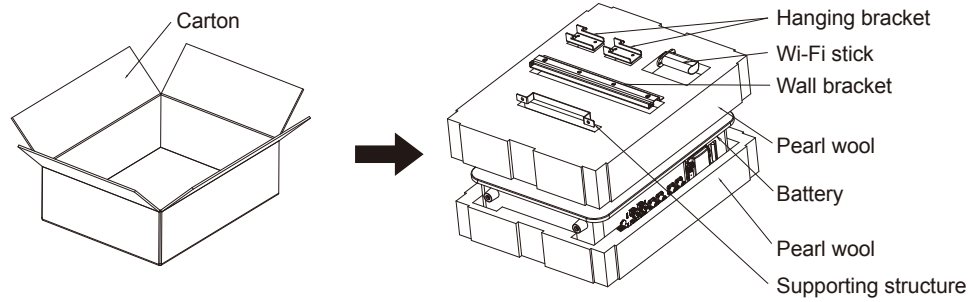

ON.	Pictures	Quantity	Description
1		1PCS	Battery
2		1PCS	Wall bracket
3		2PCS	Hanging bracket
4		1PCS	Supporting Structure
5		1PCS	Wi-Fi stick (Assembly options)
6		4PCS	M10*80
7		2PCS	M4*20
8		8PCS	M6*16
9		2PCS	M3*12 (Assembly options)
10		1PCS	Test report
11		1PCS	QA certificate

### 3.2 Tools

Model	Tools		
Installation	Knife 	Measuring tape 	Socket wrench (10 / 16mm) 
	Rubber mallet 	Cross screwdriver 	Hammer drill (68mm) 
Protection	ESD gloves 	Safety goggles 	Anti-dust respirator 
	Safety shoes 		

### 3.3 Installation Requirements

#### 3.3.1 Installation Environment Requirements

- Install the battery in the indoor environment.
- Place the battery in a secure location away from children and animals.
- Do not place the battery near any heat sources and avoid sparks.
- Do not expose the battery to moisture or liquids.
- Do not expose the battery to direct sunlight.

#### 3.3.2 Installation Carrier Requirements

- Only mount batteries on fire-resistant buildings. Do not install batteries on flammable buildings.
- Due to the quite heavy battery, make sure the wall / ground can meet the load bearing requirements.

### 3.4 Installation Instructions

#### 3.4.1 Dimensions

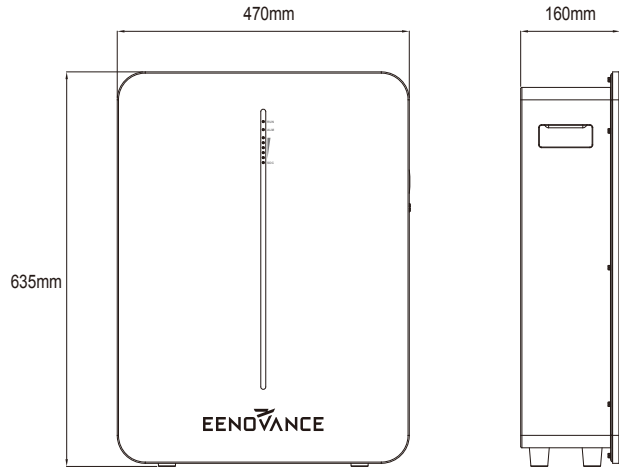

Minimum mounting distance between battery pack and equipment:

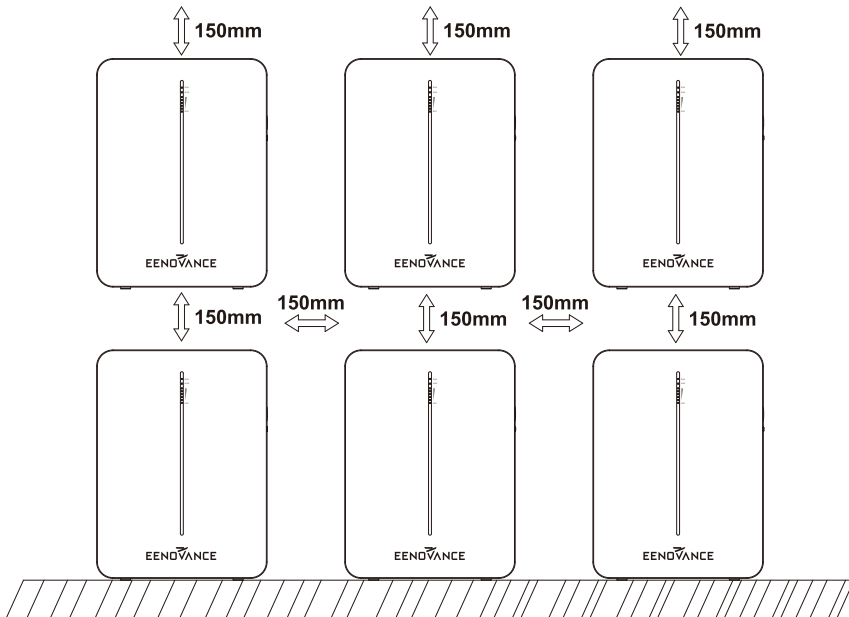

#### 3.4.2 Installation Procedure

##### STEP 1

Drill the hole with a 10mm drill bit as follows and fix the wall bracket to the wall.

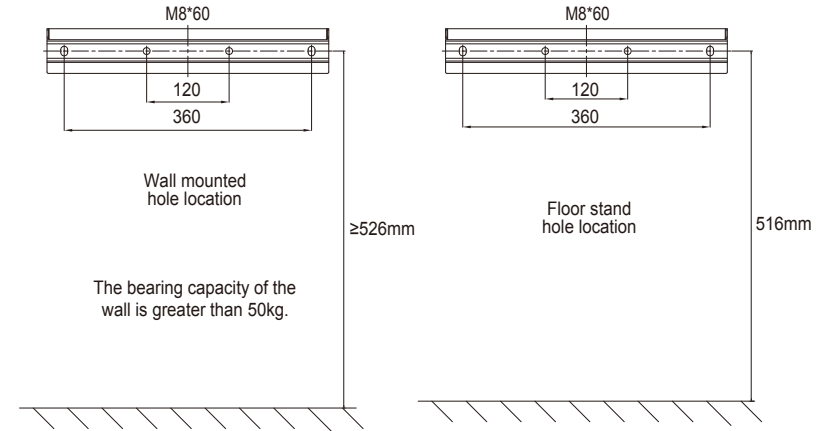

##### STEP 2

Install the hanging bracket and the supporting structure.

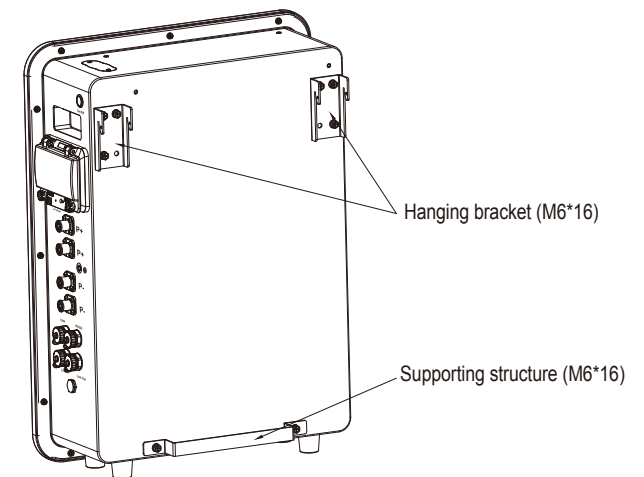

**STEP 3**

Hang MANA 5.12 Ultra on the wall bracket and tighten it.

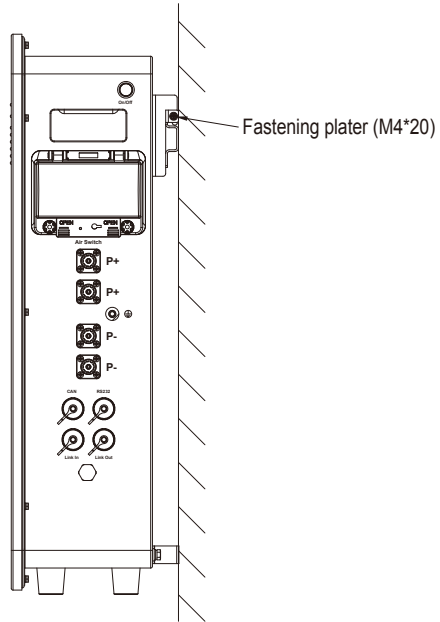

**STEP 4**

Connect to the ground.

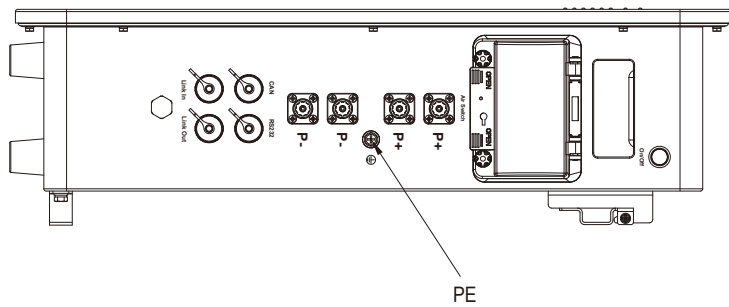

**STEP 5**

Connect the power cable.

Note that all switches are OFF before wiring.

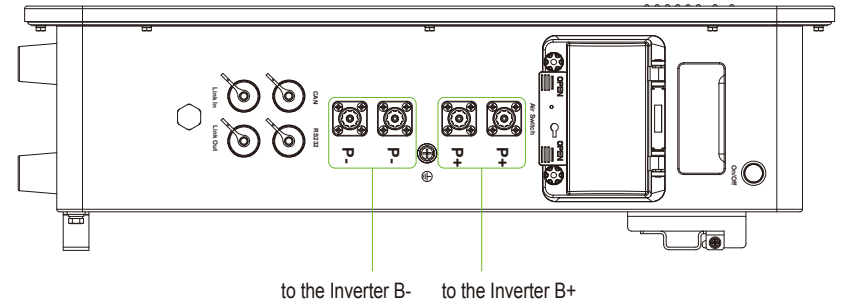

**STEP 6**

Connect the communication cable.

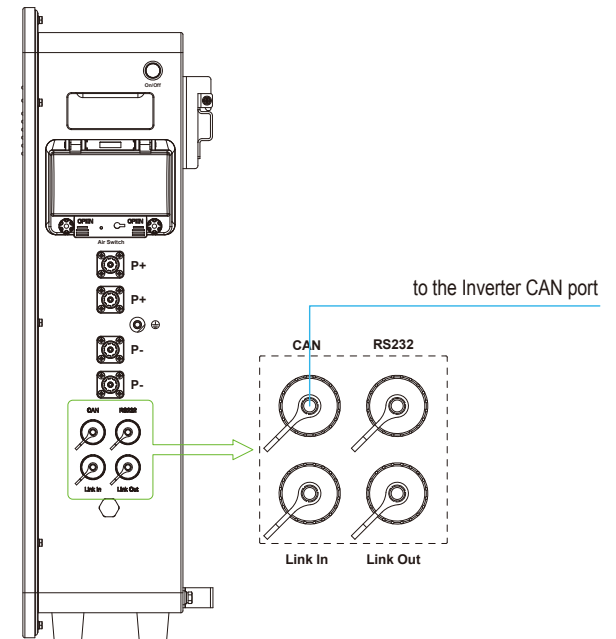



# 04 MAINTENANCE

## 4.1 Recharge Requirements During Normal Storage

Battery should be stored in an environment with temperature range between -10°C ~ +45°C, and maintained regularly according to the follow table with 0.5C (50A) current till 40% SOC after a long storage time.

**Recharge Conditions When in Storage**

Storage Environment Temperature	Relative Humidity of Storage Environment	Storage Time	SOC
Below -10°C	/	Prohibit	/
-10~25°C	5%~70%	≤12 months	30%≤SOC≤60%
25~35°C	5%~70%	≤6 months	30%≤SOC≤60%
35~45°C	5%~70%	≤3 months	30%≤SOC≤60%
Above 45°C	/	Prohibit	/

## 4.2 Recharge Requirements When Over Discharged

The over-discharged (90% DOD) battery should be recharged according to the following table, otherwise the over-discharged battery will be damaged.

**Recharge Conditions When Battery is Over Discharged**

Storage Environment Temperature	Storage Time	Note
-10~25°C	≤15 days	Battery Pack disconnected from Inverter
25~35°C	≤7 days	
-10~45°C	<12 hours	Battery Pack connected to Inverter

# 05 DISPOSAL OF THE BATTERY SYSTEM

Disposal of the battery must comply with the local applicable disposal regulations for electronic waste and used batteries.

- Do not dispose of the battery system with your household waste.
- Avoid exposing the batteries to high temperatures or direct sunlight.
- Avoid exposing the batteries to high humidity or corrosive atmospheres.